

# FLANGE-COUPPLINGS

FOUR IN ONE



[MALMEDIE.COM](http://MALMEDIE.COM)





# CONTENTS

Application _____	3
Size selection flanged hubs _____	4
Key connections _____	5
Dimension sheet flanged hubs and brake discs _____	6-7
Size selection coupling type _____	8
Size selection / operating factors _____	9
Data sheet S-LX _____	10
Data sheet S-EK _____	11
Data sheet S-TK _____	12
Data sheet S-LK _____	13
Inquiry form _____	14

# Modular Flange-Coupling System

## Applications



The Flange-Coupling series S is a modular system. First, you select the flanged hubs with brake disc (BS) or without brake disc (B) as well as the respective size need to be selected.

Second, you select the desired coupling (insert) type:

- > LX for Gear-Coupling
- > TK for Barrel-Coupling
- > EK for Elastic-Coupling
- > LK for Disc-Coupling

This results in the following type designation code (example):

### S310 - BS 710 - LX

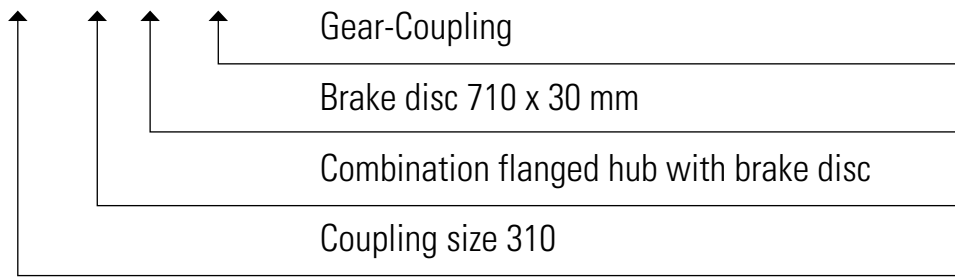

*As a standard, flanged hubs are bored with keyways according to DIN6885.*

*Shrink fit or spline connections as per DIN5480 are available special executions.*

*For the size selection, please obtain the technical data of the selected coupling type and the desired hub / shaft connection.*

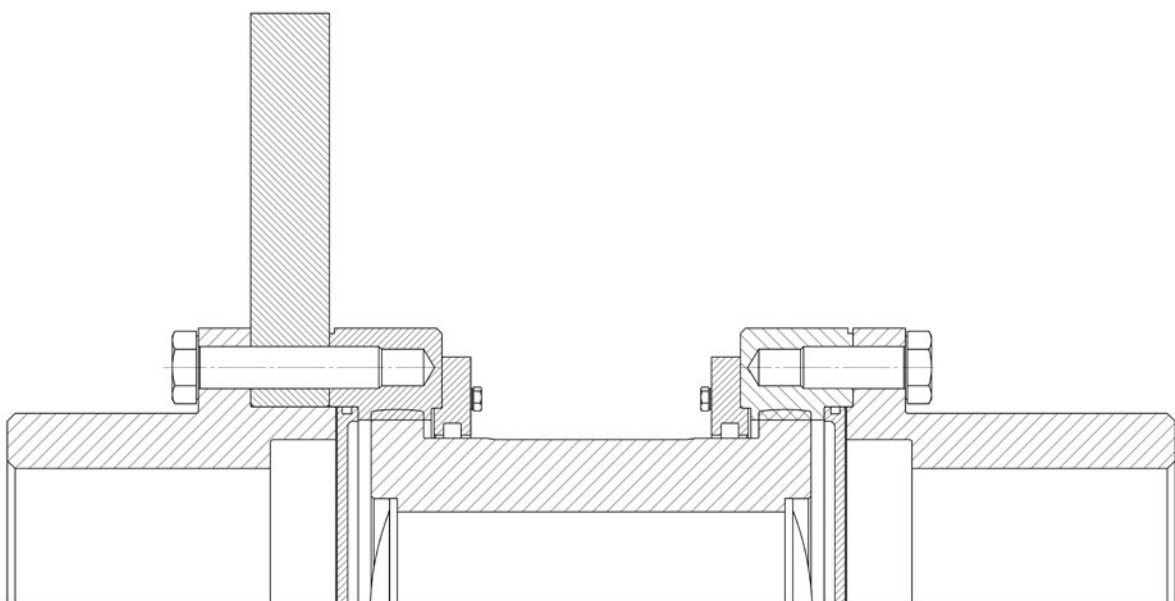

## Flange-Couplings

### Size selection flanged hubs

The size of coupling required depends on the following factors:

1. max. brake torque  $T_{Br\ max}$
2. Selection of coupling type
4. Dimension of the input and output shaft

$$T_{Br\ max} = \frac{F_{Br} \cdot d_{wirk} \cdot \mu_{Br}}{2000} \leq T_{KBr\ max}$$

For all other types of hub/shaft connection, e.g.:

- > Spline connections as per DIN5480
- > Draw key connections
- > Shrink connections

please contact our technical department.

#### 1. max. brake torque $T_{Br\ max}$ [Nm]

Determination of brake torque and brake disc diameter.

$F_{Br}$	>	installed brake contact force [N]
$d_{wirk}$	>	Friction-Ø of the installed brake disc [mm]
$\mu_{Br}$	>	max. friction coefficient of brake lining
$T_{Br\ max}$	>	max. brake torque [Nm]
$T_{KBr\ max}$	>	max. Coupling brake torque [Nm]

#### 2. Selection of coupling type and size

Selection of coupling type and size is shown on page 8. Coupling type depends on the application. MALMEDIE is at your disposal for consultation.

#### 3. Dimensions of the input and output shafts

Furthermore, a check must be made as to whether the input and/or output shaft diameters are smaller than the max. permissible bore diameter of the Flange-Coupling hubs according to the dimension sheet.

The maximum bore diameters specified within the dimension sheets apply for keyways according to DIN6885-1. In addition, all connections are to be checked for the torque transferred across the hub/shaft connection.

# Flange-Couplings

## Key connections



The given values for the bores are valid according to DIN6885-1. As a matter of principle, every key connection must be checked with regard to surface pressure. Keyways according to BS 46, ANSI B17.1 or other standards are also possible. For other types of connections, such as e.g. shrink-fit connections or spline connections in accordance with DIN5480, multiple splined shaft connections, or shrink-disc connections, please get in contact with our Technical Department.

All dimensions in mm											
<b>Bore d1</b>	from	38	44	50	58	65	75	85	95	110	
	to	44	50	58	65	75	85	95	110	130	
<b>Key</b>	Width w	12	14	16	18	20	22	25	28	32	
	Height h	8	9	10	11	12	14	14	16	18	
<b>Shaft keyway</b>	*Width w	12	14	16	18	20	22	25	28	32	
	Depth t1	5	5,5	6	7	7,5	9	9	10	11	
	Tolerance	+ 0,2									
	r2 min.	0,4				0,6					
	r2 max.	0,6				0,8					
<b>Hub keyway</b>	**Width w	12	14	16	18	20	22	25	28	32	
	Depth t1	3,3	3,8	4,3	4,4	4,9	5,4	5,4	6,4	7,4	
	Tolerance	+ 0,2									
	r2 min.	0,4				0,6					
	r2 max.	0,6				0,8					

<b>Bore d1</b>	from	130	150	170	200	230	260	290	330	380	440	
	to	150	170	200	230	260	290	330	380	440	500	
<b>Key</b>	Width w	36	40	45	50	56	63	70	80	90	100	
	Height h	20	22	25	28	32	32	36	40	45	50	
<b>Shaft keyway</b>	*Width w	36	40	45	50	56	63	70	80	90	100	
	Depth t1	12	13	15	17	20	20	22	25	28	31	
	Tolerance	+ 0,3										
	r2 min.	1			1,6				2,5			
	r2 max.	1,2			2				3			
<b>Hub keyway</b>	**Width w	36	40	45	50	56	63	70	80	90	100	
	Depth t1	8,4	9,4	10,4	11,4	12,4	12,4	14,4	15,4	17,4	19,5	
	Tolerance	+ 0,3										
	r2 min.	1			1,6				2,5			
	r2 max.	1,2			2				3			

### \* Tolerance width w of the shaft keyway

tight fit > P9  
loose fit > N9

### \*\* Tolerance width w of the hub keyway

tight fit > P9  
loose fit > JS9

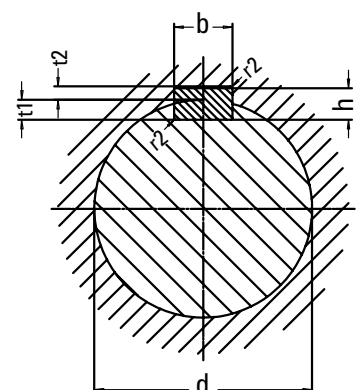
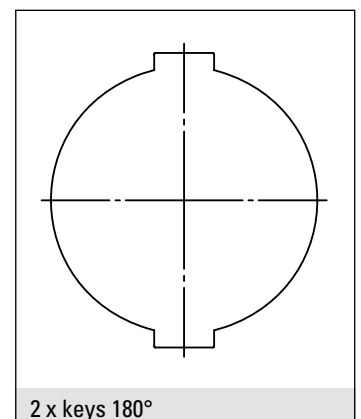
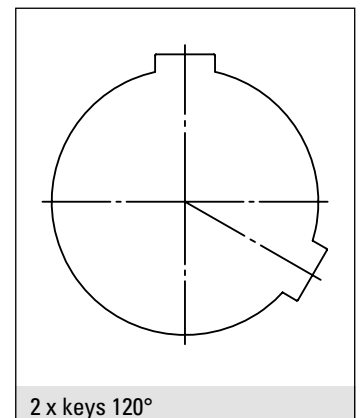
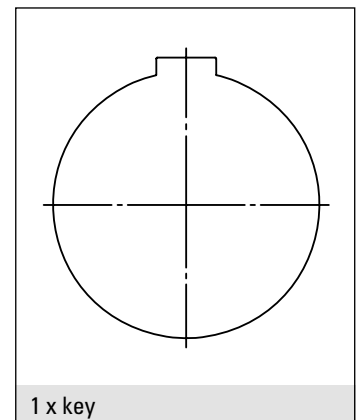

# Flange-Couplings

## Dimension sheet flanged hubs and brake discs

(1) The torques stated do not refer to the connection of shaft and hub. If necessary, these must be checked.

(2) Balancing is available, please consult technical department.

(3) The values specified for the bores are valid for key connections according to DIN6885-1 (see page 5).

(4) With reference to the max. finish bore.

Coupling hubs shall be secured against axial movement, e.g. with end plates acc. to DIN15095.

### Flanged hub BS >>>

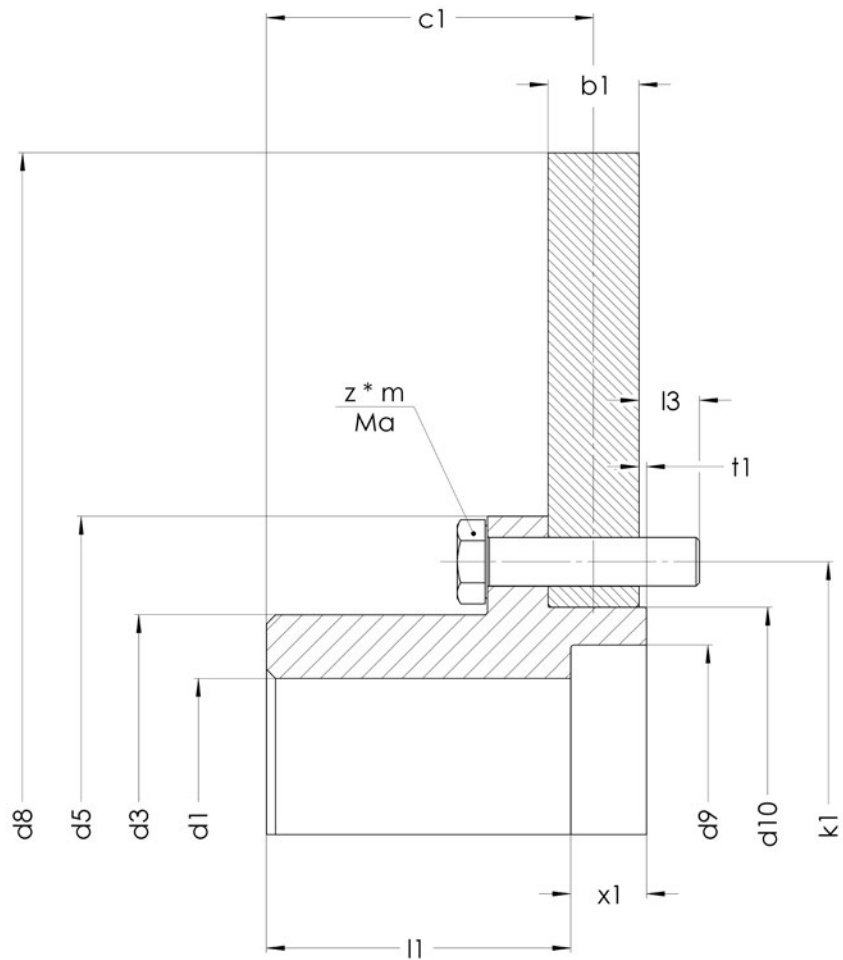

### Flanged hub B >>>

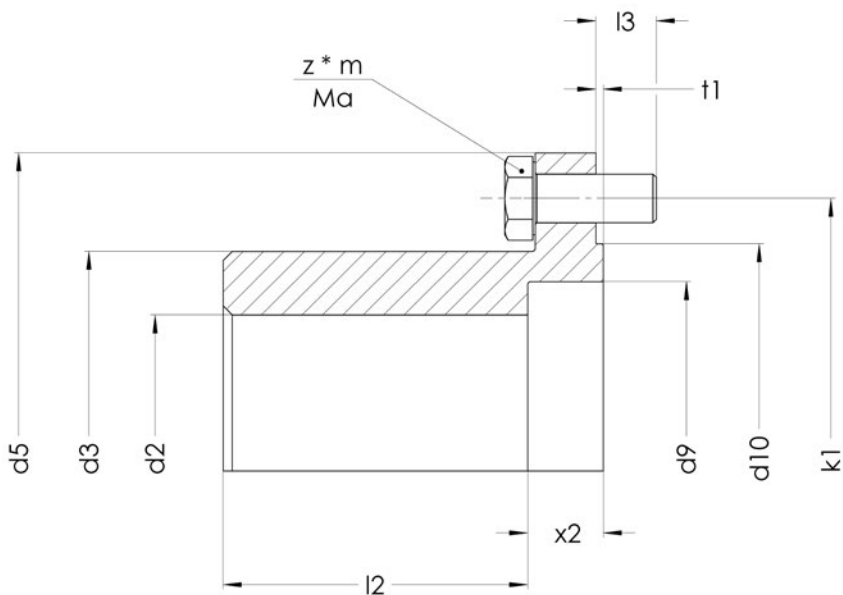

# Flange-Couplings

## Dimension sheet flanged hubs and brake discs



Size d5			150	165	180	210	230	255	310	340	400
Max. speed at max. disc Ø	(2)	min-1	4300	3800	3400	2700	2400	2150	2150	1900	1900
d1/d2 pilot bore / max. bore Ø	(3)	mm	28	28	38	38	48	58	68	78	88
		mm	69	80	90	103	117	135	160	182	210
d3		mm	97	112	127	145	165	190	225	255	295
d10 g7		mm	99	115	130	150	172	197	227	257	298
k1		mm	125	140	155	180	200	225	270	300	350
d9		mm	84	95	105	125	140	160	190	210	240
c1		mm	150	150	150	190	190	195	195	235	235
s2		mm	150	150	150	200	200	200	250	250	250
t1		mm	2	2	2	2,5	2,5	2,5	3	3	3
l1		mm	147	147	147	182,5	182,5	187,5	183	223	223
l2		mm	70	80	90	100,5	120,5	140,5	160	175	200
l3		mm	15	15	15	20	20	20	25	25	25
x1, x2		mm	20	20	25	25	25	30	30	30	
z			16	16	20	16	20	20	20	24	24
m			M12	M12	M12	M16	M16	M16	M20	M20	M24
Tightening torque Ma		Nm	115	115	115	290	290	290	560	560	970
Brake disc Ø d8 x b1		mm	Weight / Mass moment of inertia (4)								
355 x 30		kg	29,957	32,296							
		kgm <sup>2</sup>	0,384	0,396							
400 x 30		kg	36,241	38,581	41,533						
		kgm <sup>2</sup>	0,609	0,621	0,638						
450 x 30		kg		46,441	49,394	60,840					
		kgm <sup>2</sup>		0,977	0,995	1,080					
500 x 30		kg			58,179	69,626	77,308				
		kgm <sup>2</sup>			1,492	1,577	1,660				
560 x 30		kg				81,390	89,072	99,737			
		kgm <sup>2</sup>				2,406	2,489	2,635			
630 x 30		kg				96,797	104,479	115,145	132,437		
		kgm <sup>2</sup>				3,774	3,857	4,003	4,343		
710 x 30		kg					124,307	134,972	152,265	177,846	219,603
		kgm <sup>2</sup>					6,090	6,237	6,576	7,105	8,378
800 x 30		kg						160,109	177,401	202,982	244,739
		kgm <sup>2</sup>						9,831	10,171	10,700	11,972
900 x 30		kg								234,426	276,182
		kgm <sup>2</sup>								16,399	17,672



## Flange-Couplings

### Size selection coupling type

Required coupling size depends on the following factors:

1. max. brake torque  
 $T_{Br\ max}$
2. max. drive torque  
 $T_{nenn}$
3. max. plant shock torque  
 $T_{max}$
4. Operational speed  $n$
5. Dimensions of input and output shaft

$$T_{Br\ max} \leq T_{KB\ max}$$

$$T_{nenn} = \frac{N \cdot 9550}{n} \cdot K_1 \cdot K_2 \leq T_{KN}$$

$$\begin{aligned} T_{max} &\leq T_{Kmax} \\ T_{max} &\leq T_{KBR\ max} \end{aligned}$$

#### 1. Max. torques $T_{Br\ max}$ [Nm]

Determination of required brake torque and required brake disc  $\emptyset$ .

$$\begin{aligned} T_{Br\ max} &> \text{max. Brake torque [Nm]} \\ T_{KBr\ max} &> \text{max. Coupling brake torque [Nm]} \end{aligned}$$

#### 2. Max. drive torque $T_{nenn}$ [Nm]

$$\begin{aligned} N &= \text{plant power output [kW]} \\ n &= \text{coupling rotational speed [rpm]} \\ K_1 &= \text{operating factor, taken from the "Type of drive" table, page 9} \\ K_2 &= \text{operating factor, taken from the "Type of loading" table, page 9} \\ T_{KN} &= \text{coupling torque, taken from data sheets [Nm], page 10-13} \end{aligned}$$

#### 3. Max. plant shock torque $T_{max}$ [Nm]

$$\begin{aligned} T_{max} &= \text{plant shock torque or starting torque [Nm]} \\ T_{Kmax} &= \text{max. coupling torque, taken from the data sheets [Nm]} \end{aligned}$$

The max. plant shock torque  $T_{max}$  must be less than the max. coupling torque  $T_{kmax}$ , otherwise a larger coupling must be selected. MALMEDIE is at your disposal to consult you accordingly.

#### 4. Selection of coupling type

The required coupling size in combination with the max. plant shock torque  $T_{max}$  is shown in the relevant data sheets.

Gear-Coupling	S-LX	Page 10
Elastic-Coupling	S-EK	Page 11
Barrel-Coupling	S-TK	Page 12
Disc-Coupling	S-LK	Page 13



# Flange-Couplings

## Size selection / Operating factors



Type of drive	K <sub>1</sub> operating factor		
	Daily operation, duration up to 12 hours		Daily operation, duration above to 12 hours
Electric motor, turbine	1.1		1.15
Hydraulic motor	1.2		1.25
Combustion engine	1.4		1.5
Type of loading	Operation	K <sub>2</sub> operating factor	Working machine
SMOOTH	Continuous operation without overload	1.0 – 1.25	Light ventilation fans Radial pumps Electrical generators Centrifugal pumps Stirrers (low viscosity liquids)
LIGHT DUTY	Continuous operation with light overloads and brief, infrequent shock loads	1.25 – 1.5	Large ventilation fans Piston pumps Stirrers (high viscosity liquids) Textile machinery Machine tools Belt conveyors Elevator
MEDIUM DUTY	Operation with frequent light shock loads and brief, medium level overloads	1.5 – 1.8	Piston compressors Conveyor machinery Calenders Briquetting presses Non-reversing rolling mills Smoothing machinery Winches
HEAVY DUTY	Operation with heavy and frequent shock loads. Frequent load reversals. High level of safety.	1.8 – 2.2	Cranes, elevators (heavy load operations) Mixers Rolling lines Reversing rolling mills Kneading machinery Punching machinery Shears
VERY HEAVY DUTY	Operation with very heavy and frequent shock loads. Frequent and sudden load reversals. Very high level of safety.	> 2.2	Reversing rolling mills Heavy load operations in the steel industry Shearing and cutting units Forging presses Billet shears Hammers Stone breakers / milling machinery
The K <sub>2</sub> operating factors specified are average values.			

## Flange-Couplings Data sheet S-LX (Gear-Coupling)

(1) The torques stated do not refer to the connection of shaft and hub. If necessary, these must be checked.

(2) Balancing is available, please consult technical department.

Coupling hubs shall be secured against axial movement, e.g. with end plates acc. to DIN15095.

Size d5			150	165	180	210	230	255	310	340	400
TK Br max	(1)	Nm	2250	2500	3750	8750	12000	13500	28000	37000	60000
TK KN	(1)	Nm	1125	1250	1875	4375	6000	6750	14000	18500	30000
TK max	(1)	Nm	6240	10100	15100	23700	35600	48000	72000	108000	162000
max. Speed at max. disc Ø	(2)	min-1	4300	3800	3400	2700	2400	2150	2150	1900	1900
d5		mm	150	165	180	210	230	255	310	340	400
d9		mm	84	95	105	125	140	160	190	210	240
s1		mm	186	186	186	245	235	245	304	304	304
x1, x2		mm	20	20	20	25	25	25	30	30	30
s2		mm	150	250	150	200	200	200	250	250	300

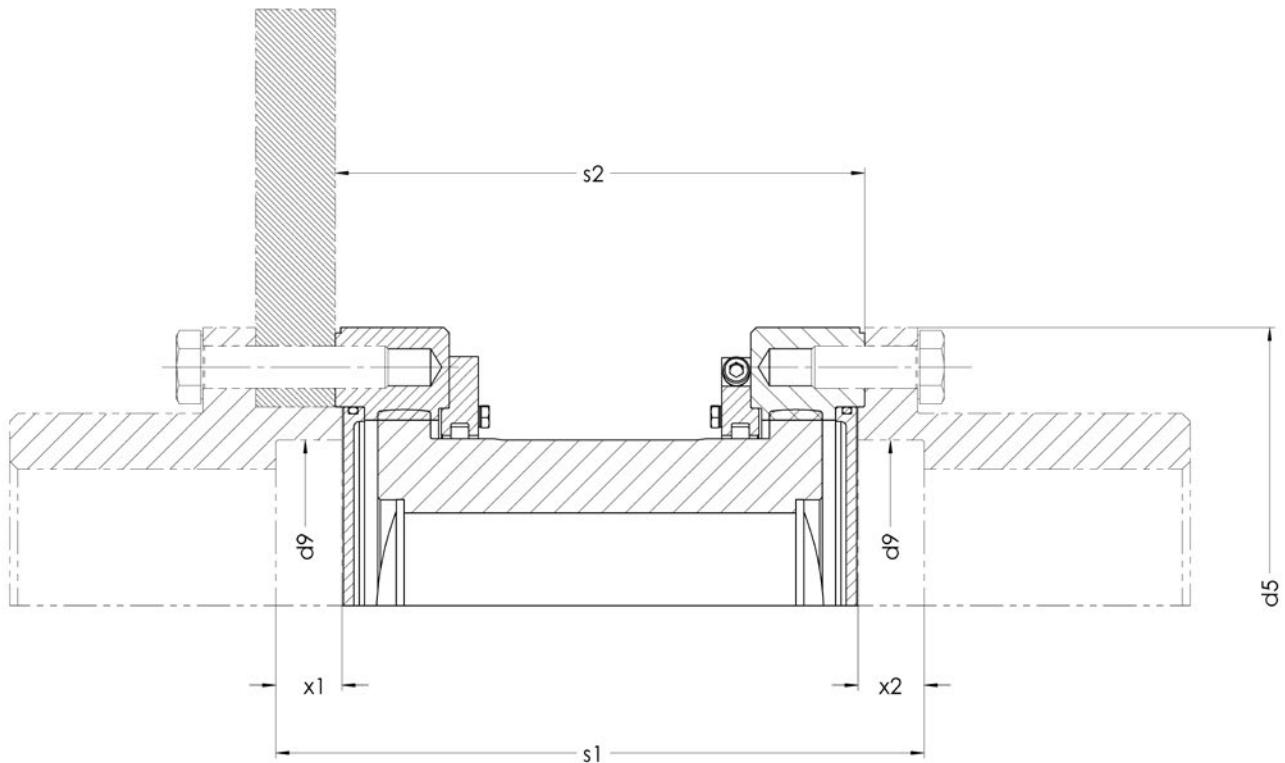

# Flange-Couplings

## Data sheet S-EK (Elastic-Coupling)



Size d5			150	165	180	210	230	255	310	340	400
TK Br max	(1)	Nm	2250	2500	3750	8750	12000	13500	28000	37000	60000
TK KN	(1)	Nm	1125	1250	1875	4375	6000	6750	14000	18500	30000
TK max	(1)	Nm	3730	5210	6936	18462	22792	32820	54340	64670	81854
max. Speed at max. disc Ø	(2)	min-1	4300	3800	3400	2700	2400	2150	2150	1900	1900
d5		mm	150	165	180	210	230	255	310	340	400
d6		mm	200	200	225	254	290	320	370	380	440
d9		mm	84	95	105	125	140	160	190	210	240
s1		mm	186	186	186	245	245	245	304	304	304
x1, x2		mm	20	20	20	25	25	25	30	30	30
s2		mm	150	250	150	200	200	200	250	250	300

(1) The torques stated do not refer to the connection of shaft and hub. If necessary, these must be checked.

(2) Balancing is available, please consult technical department.

Coupling hubs shall be secured against axial movement, e.g. with end plates acc. to DIN15095.

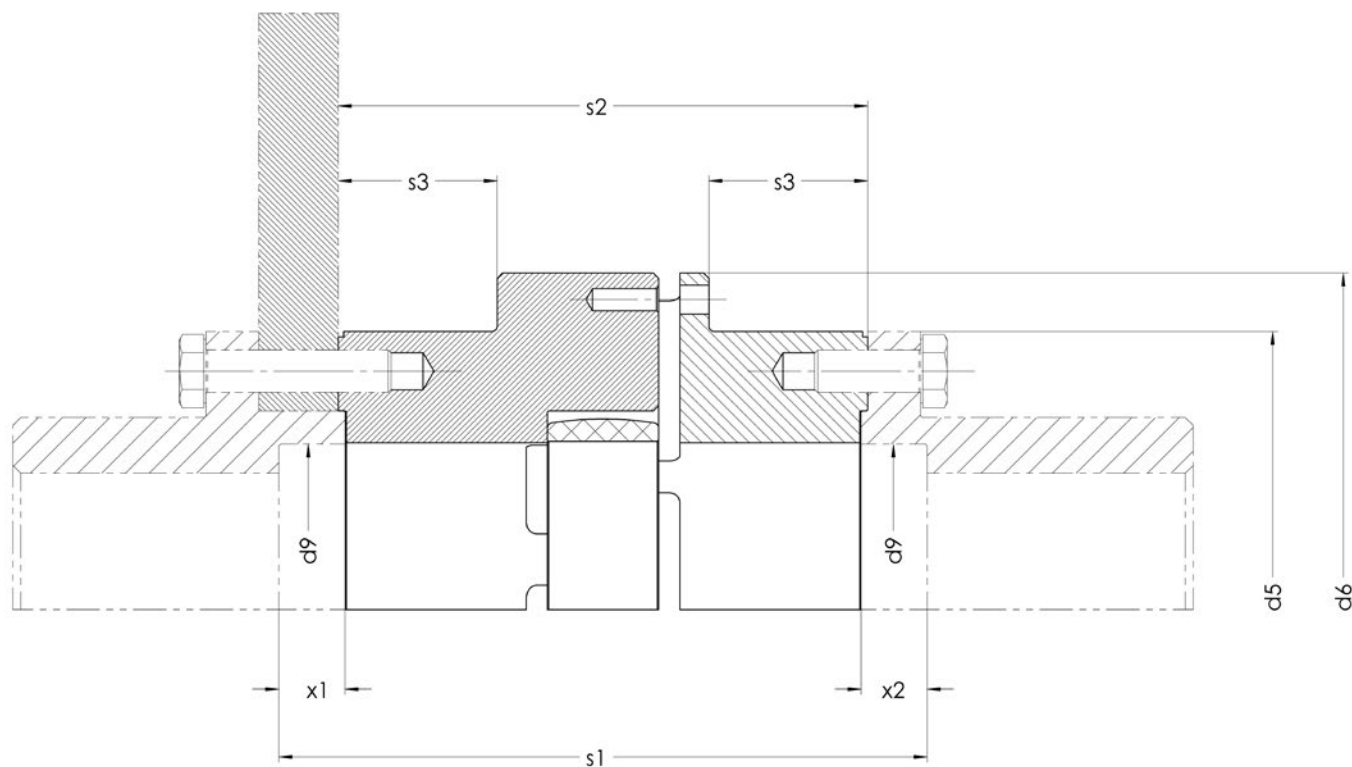

## Flange-Couplings Data sheet S-TK (Barrel-Coupling)

(1) The torques stated do not refer to the connection of shaft and hub. If necessary, these must be checked.

(2) Balancing is available, please consult technical department.

Coupling hubs shall be secured against axial movement, e.g. with end plates acc. to DIN15095.

Size d5			150	165	180	210	230	255	310	340	400
TK Br max	(1)	Nm	2250	2250	3750	8750	12000	13500	28000	37000	60000
TK KN	(1)	Nm	3920	5480	7300	10500	12970	18600	47390	56300	74400
TK max	(1)	Nm	7840	10960	14600	21000	25940	33500	85300	101500	140000
max. Speed at max. disc Ø	(2)	min-1	4300	3800	3400	2700	2400	2150	2150	1900	1900
d5		mm	150	165	180	210	230	255	310	340	400
d9		mm	84	95	105	125	140	160	190	210	240
s1		mm	186	186	186	245	245	245	304	304	304
x1, x2		mm	20	20	20	25	25	25	30	30	30
s2		mm	150	250	150	200	200	200	250	250	300

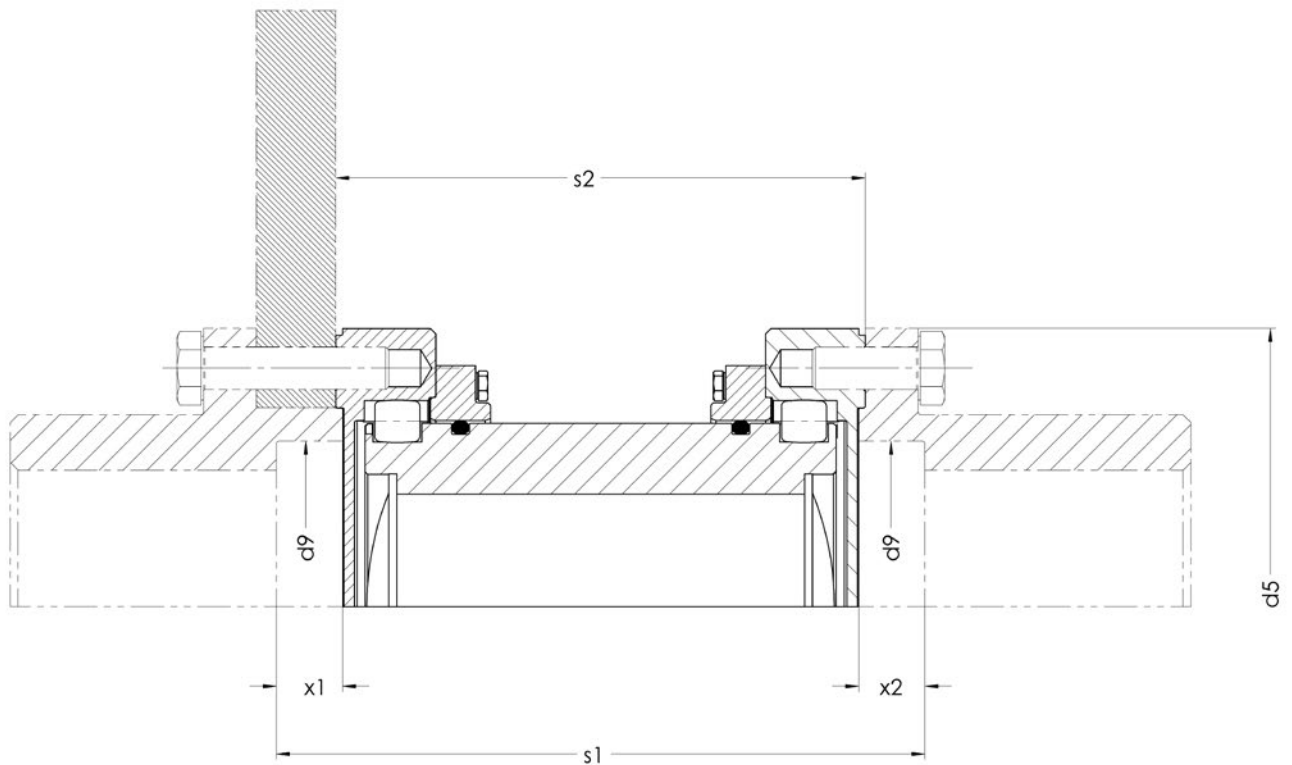

# Flange-Couplings

## Maßblatt S-LK (Lamellen-Kupplung)



Size d5			150	165	180	210	230	255	310	340	400
TK Br max	(1)	Nm	2250	2500	3750	8750	12000	13500	28000	37000	60000
TK KN	(1)	Nm	Werte auf Anfrage								
TK max	(1)	Nm	Werte auf Anfrage								
max. Speed at max. disc Ø	(2)	min-1	4300	3800	3400	2700	2400	2150	2150	1900	1900
d5		mm	150	165	180	210	230	255	310	340	400
d6		mm	200	210	230	260	280	310	370	390	450
d9		mm	84	95	105	125	140	160	190	210	240
s1		mm	186	186	186	245	245	245	304	304	304
x1, x2		mm	20	20	20	25	25	25	30	30	30
s2		mm	150	250	150	200	200	200	250	250	300

(1) The torques stated do not refer to the connection of shaft and hub. If necessary, these must be checked.

(2) Balancing is available, please consult technical department.

Coupling hubs shall be secured against axial movement, e.g. with end plates acc. to DIN15095.

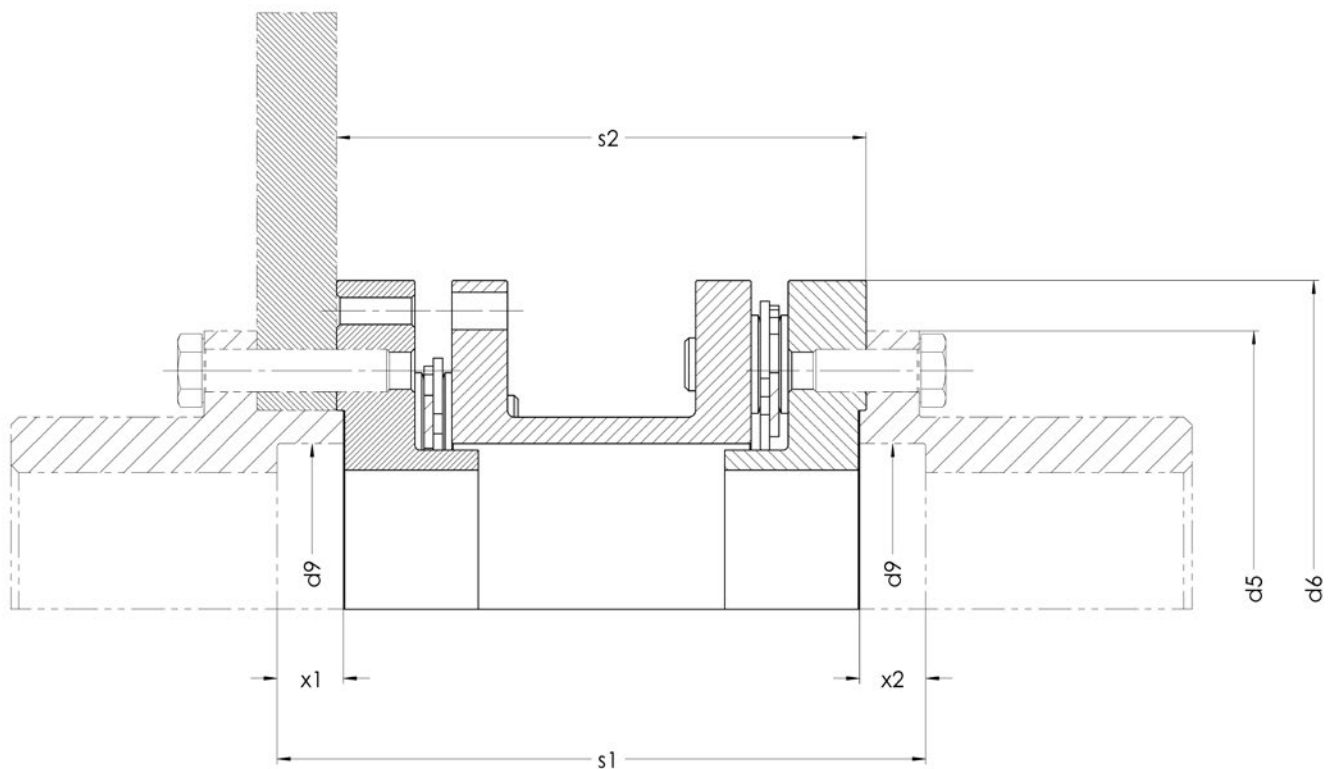



# Inquiry form for Flange-Couplings

Company

\_\_\_\_\_  
\_\_\_\_\_  
\_\_\_\_\_

Contact Person

\_\_\_\_\_  
\_\_\_\_\_  
\_\_\_\_\_

Str. / No:

\_\_\_\_\_  
\_\_\_\_\_  
\_\_\_\_\_

Postcode / Town

\_\_\_\_\_  
\_\_\_\_\_  
\_\_\_\_\_

Country

\_\_\_\_\_  
\_\_\_\_\_  
\_\_\_\_\_

Phone

\_\_\_\_\_  
\_\_\_\_\_  
\_\_\_\_\_

Fax

\_\_\_\_\_  
\_\_\_\_\_  
\_\_\_\_\_

Email

\_\_\_\_\_  
\_\_\_\_\_  
\_\_\_\_\_

## Place of use

Project \_\_\_\_\_

Working machine \_\_\_\_\_

## Operation

	SMOOTH	1.00 - 1.25	Continuous operation without overload or shock loads.
	LIGHT DUTY	1.25 - 1.50	Continuous operation with light overloads and brief infrequent shock loads.
	MEDIUM DUTY	1.50 - 1.80	Operation with frequent light shock loads and brief, medium level overloads.
	HEAVY DUTY	1.80 - 2.20	Operation with heavy and frequent shock loads. Frequent load reversals: High level of safety.
	VERY HEAVY DUTY	> 2.20	Operation with very heavy and frequent shock loads. Frequent and sudden load reversals. Very high level of safety.

Direction of force

- constant  
 alternating

Operations per hour \_\_\_\_\_ / h

Operational duration per day \_\_\_\_\_ h/d

Ambient temperature \_\_\_\_\_ °C

## Technical data

Type of drive  Electric motor, turbine  Hydraulic motor  Combustion engine

Motor power output \_\_\_\_\_ kW

Motor rotational speed \_\_\_\_\_ U/min

Gear transmission ratio \_\_\_\_\_

Gear efficiency \_\_\_\_\_

Coupling rotational speed \_\_\_\_\_ U/min

Nominal torque \_\_\_\_\_ kNm  without operating factor  with operating factor

max. torque \_\_\_\_\_ kNm  without operating factor  with operating factor

## Design

Coupling type \_\_\_\_\_ Coupling size \_\_\_\_\_ (pre-selection) Overall length \_\_\_\_\_

### Hub-shaft connection

1.) Coupling hub Bore diameter \_\_\_\_\_  
Shaft diameter \_\_\_\_\_

Keyway Quantity \_\_\_\_\_  
Angle \_\_\_\_\_

DIN5480-gearing

Shrink-fit connection

Other

### Hub-shaft connection

2.) Coupling hub Bore diameter \_\_\_\_\_  
Shaft diameter \_\_\_\_\_

Keyway Quantity \_\_\_\_\_  
Angle \_\_\_\_\_

DIN5480-gearing

Shrink-fit connection

Other

## Remark

\_\_\_\_\_  
\_\_\_\_\_  
\_\_\_\_\_  
\_\_\_\_\_



## CONTACT

M.A.T.

**MALMEDIE**

ANTRIEBSTECHNIK GMBH

Dycker Feld 28

42653 Solingen

Germany

T +49 212 / 258 11-0

F +49 212 / 258 11-31

[www.malmedie.com](http://www.malmedie.com)

[info@malmedie.com](mailto:info@malmedie.com)



M.A.T.

**MALMEDIE**

ANTRIEBSTECHNIK GMBH

Dycker Feld 28

42653 Solingen

Germany

T +49 212 / 258 11-0

F +49 212 / 258 11-31

[www.malmedie.com](http://www.malmedie.com)

[info@malmedie.com](mailto:info@malmedie.com)

**MALMEDIE.COM**